

Specifications of G-Tools

Standard straight type



UNR-G613-400NT



UNR-G640-1300NT

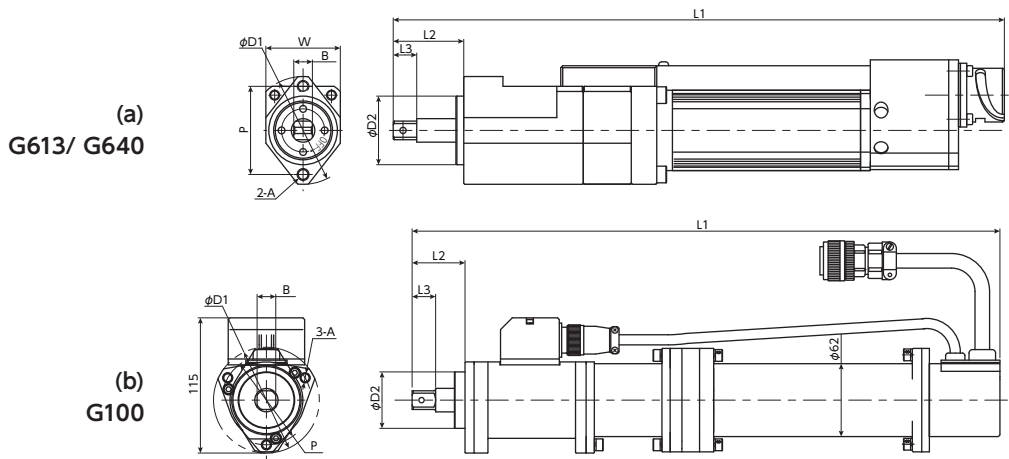

Dimensions

Type	External dimensions (mm)									Fixing plate thickness	Motor type	Torque sensor	Flange design
	L1	L2	L3	W	φD1	φD2	P	A	B				
UNR-G613-50NT	288							M6	9.5sq	9.0以上	G613	Built-in the motor	(a)
UNR-G613-100NT													
UNR-G613-200NT	312	36	12	38	55	35	45						
UNR-G613-300NT													
UNR-G613-400NT	419	40		51	73	44	59	M8	15.88sq				
UNR-G640-800NT													
UNR-G640-1000NT	516	45		115	90	48	φ76		19.0sq	12.0以上	G100		(b)
UNR-G640-1300NT													
UNR-G100-1900NT	570	57	30	120.5	94	58							
UNR-G100-2500NT													
UNR-G100-3700NT	654	80	40	150.5	128	70	φ90	M10	25.4sq				
UNR-G100-5400NT													
UNR-G100-7000NT													
UNR-G100-10000NT													

Torque sensor specifications

Type	Capacity (Nm)
10N	9
40N	34
130N	105
250N	195
370N	280
700N	540
1000N	800
Rated strain	1000×10-6
Output voltage	0.5mV/V
Non-linearity	0.5%R.O.
Influence on zero point due to temperature	0.025%R.O./°C
Temperature rating	-10~+65°C
Input output resistance	350Ω
Maximum input voltage	Max.16V
Insulation resistance	300MQ以上
Overload capacity	150%R.O.

Specifications	Type	Max. Torque		Free Speed (rpm)	Weight		Spindle unit
		(Nm)	(ft-lbs)		(kg)	(lb)	
Small size	UNR-G613-50NT	5	3.7	5350	1.32	2.91	UEC-G024
	UNR-G613-100NT	10	7.4	3000	1.32	2.91	
	UNR-G613-200NT	20	14.8	1220	1.55	3.42	
	UNR-G613-300NT	30	22.2	860	1.55	3.42	
	UNR-G613-400NT	40	29.6	640	1.55	3.42	
Medium size	UNR-G640-800NT	80	59.2	940	4.0	8.82	UEC-G060
	UNR-G640-1000NT	100	74.0	760	4.0	8.82	
	UNR-G640-1300NT	130	96.2	560	4.0	8.82	
Large size	UNR-G100-1900NT	190	140.6	720	8.4	18.52	UEC-G120
	UNR-G100-2500NT	250	185.0	530	8.7	19.18	
	UNR-G100-3700NT	370	273.8	370	10.2	22.49	
	UNR-G100-5400NT	540	399.6	250	16.0	35.27	
	UNR-G100-7000NT	700	518.0	170	16.0	35.27	
	UNR-G100-10000NT	1000	740.0	130	16.0	35.27	

G-Tools minimum pitch circle

Refer to minimum pitch circle for your machine designing.

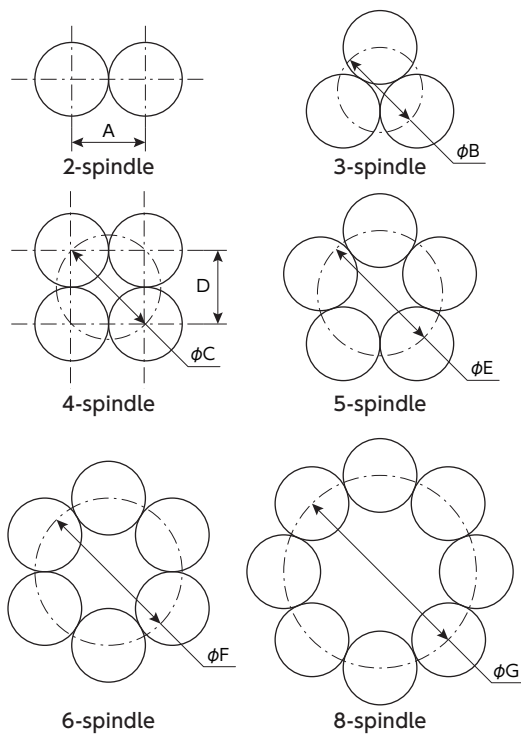

Type	A	φB	φC	D	φE	φF	φG
UNR-G613-50NT	39	49	61	44	67	80	104
UNR-G613-100NT							
UNR-G613-200NT							
UNR-G613-300NT							
UNR-G613-400NT							
UNR-G640-800NT	52	65	81	58	89	107	138
UNR-G640-1000NT							
UNR-G640-1300NT							
UNR-G100-1900NT	69	85	105	75	115	132	174
UNR-G100-2500NT							
UNR-G100-3700NT	94	125	143	102	166	188	257
UNR-G100-5400NT							
UNR-G100-7000NT							
UNR-G100-10000NT							